



High-Lift Transmission Jacks

SINGLE STAGE

- Overall max height of 74 3/4"
- Release valve designed for controlled lowering
- Head can be tilted 15° forward and 10° backward for proper alignment of splines and bolt holes
- Adapter and safety chain included



LA815

TWO STAGE

- Rugged and stable enough to handle car and light truck transmissions
- Carrier tilts for precise alignment
- Two-stage hydraulic ram
- Wide base with swivel casters assures safe, stable load distribution
- Specially finished ram, pump and piston ensure prolonged seal life
- Safety chain included

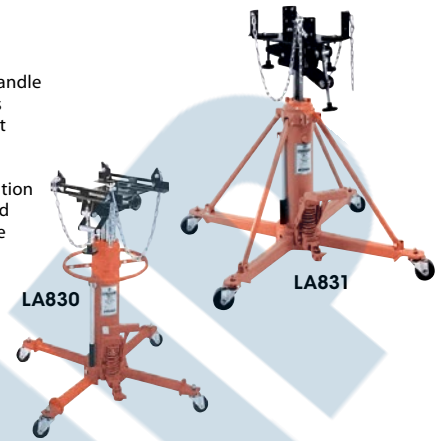

LA830

LA831

STRONGARM

Model No.	Capacity lbs.	Stage	Lowered Height"	Raised Height"	Forward Tilt	Backward Tilt	Left Tilt	Right Tilt	Wt. lbs.	Price /Each
LA815	1000	Single	45	71	30°	15°	-	-	96	
LA830	1000	Two	33 1/2	72 1/2	40°	15°	50°	20°	203	
LA831	2000	Two	33 1/2	72 1/2	40°	15°	50°	20°	242	

Heavy-Duty Clutch Jacks

- Designed to make installation, removal and transportation of 14" and 15 1/2" truck clutches simple for one technician
- Patented clutch head assembly turns 360° and can pivot up and down
- Optional accessories make this a versatile tool for around the shop
- Includes 2" and 1 3/4" splines
- Minimum height: 13"
- Maximum height: 39"
- Capacity: 500 lbs.
- Weight: 138 lbs.

Model No. LT221
Price/Each \$



LT221

STRONGARM

ACCESSORIES

Model No.	Description	Wt. lbs.	Price /Each
LT225	Flywheel Adaptor	6	
LT226	Drive Shaft Adaptor	18	
LT229	Differential Adaptor	30	



LT225



LT226



LT229

10" x 14" Caution Signs

- Black letters on yellow field
- Material: Vinyl
- Display Type: Adhesive



SGM049



SEE554

Model No.	Description	Price /Each
SGM049	English Caution Sign	
SEE554	French Caution Sign	

Rail Chocks

- These rugged steel rail chocks provide an effective means of blocking railcars for safe loading and unloading
- Steel points on chock heads bite into rail to prevent sliding. Standard finish in railroad maintenance yellow
- Integral 7 1/2" x 9 1/2" sign reads "chock"
- Single rail chock for stoppage in one direction; double rail chock for stoppage in both directions (with rubber strap and hooks for greater tension)
- Choice of exposed (above ground) or flush (level with ground) chocks



KH021



KH015

Model No.	Description	Wt. lbs.	Price /Each
FOR EXPOSED RAIL			
KH016	Single Chock	12	
KH021	Double Chock	16	
FOR FLUSH RAIL			
KH015	Single Chock	12	
KH020	Double Chock	16	