

DESCRIPTION

Stainless steel drinking fountain, grade 304, finish # 4, gauge # 14, for 2 users, including wall bracket, bubbler(s) and 1 ½ in Ø drain

Meets standards :

ASME A112.19.3 / CSA B45.4-08 (R2013)

CSAB125.1, NSF/ANSI 61

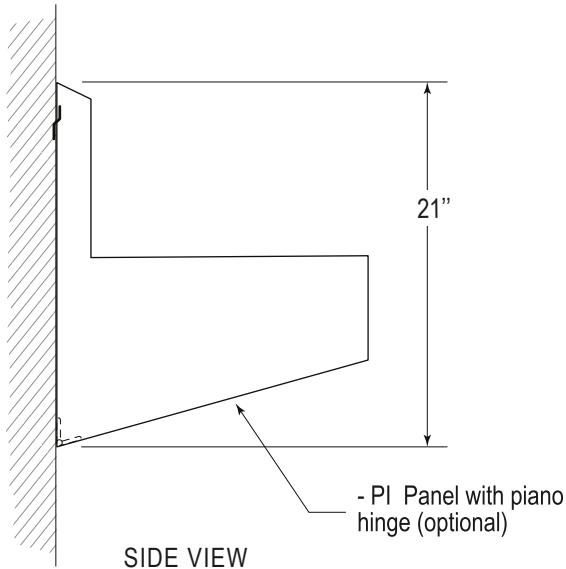

Standard models	Number of bubblers	A Length	
		in	mm
CA-FAI372118	2	37	940

Note: This dimension is nominal, the exact dimension of construction should be verified by the contractor.

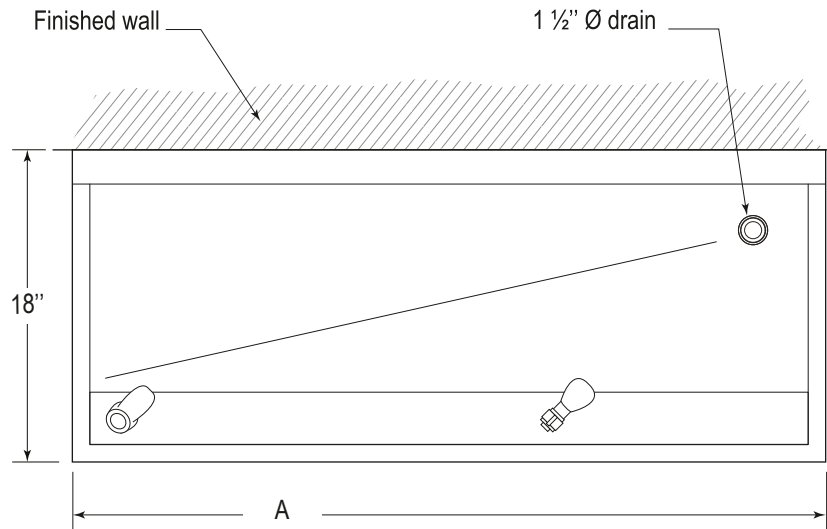

PLAN VIEW