

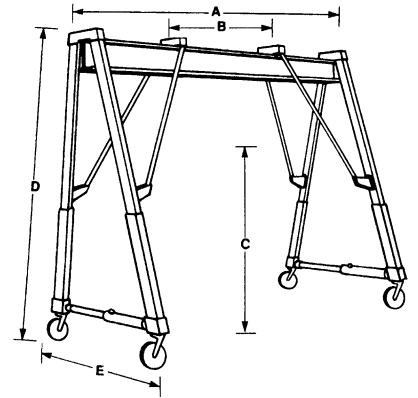

F.O.B. VAUDREUIL, QC. ITEMS ON THIS PAGE ARE MADE TO ORDER AND ARE NON-RETURNABLE

Adjustable Gantry Cranes

- Adjustable gantry cranes move and lift heavy equipment with ease
- Height adjustable between 8' and 14'
- Equipped with four heavy-duty steel swivel casters with wheel brakes
- H-Beams use flat-wheel trolleys; I-Beams use taper-wheel trolleys.
- Can be fitted with or without casters
- Shipped knocked down



Model No.	Lifting Cap. lbs.	O.A. Span A'	Clear Span B	Hook Lift Min/Max C	O.A. Height Min/Max D	Beam Height E"	Wheel Spread Min/Max F	Unit Beam Width"	Wt. lbs.	Price /Each
LA189	2000	10	47"	6'8"/11'6"	8'9"/14'7"	6	4'7"/7"	3 3/8	885	
LA190	2000	15	9'7"	6'6"/11'10"	8'9"/14'7"	8	4'7"/7"	5 1/4	1050	
LA191	4000	10	4'7"	6'2"/11'10"	8'9"/14'7"	8	4'7"/7"	4	1175	
LA192	4000	15	9'7"	6'/11'8"	8'9"/14'7"	10	4'7"/7"	5 3/4	1370	
LA193	6000	10	4'7"	5'/11'1"	8'9"/14'9"	10	4'10"/7'3"	4 5/8	1430	
LA194	6000	15	9'7"	5'/11'1"	8'9"/14'9"	10	4'10"/7'3"	5 3/4	1615	

Note: Crane only, hoist and trolley not included.

Portable Floor Cranes

- Lifts, lowers, positions and moves up to 2000 lbs. with ease
- Hand operated hydraulic pump lifts fully extended boom over 8'
- Crane moves easily with smooth rolling casters
- Fully collapsible, knocks down in seconds for easy storage
- Each crane supplied with 30" adjustable chain and hook
- Shipped knocked down

Folded for Storage



Model No.	Cap. lbs.	Overall Height"	Overall Length"	Overall Width"	Caster Type	Wt. lbs.	Price /Each
LA572	1000	69.25	63.5	31	Phenolic	260	
LA567	2000	69.25	63.5	37	Cast Iron	275	
LA838	Replacement Hydraulic Pump						

Model No.	Boom Reach"/Capacity lbs.			
	1st position	2nd position	3rd position	4th position
LA572	56.5/1000	63.5/770	70.5/320	N/A
LA567	52.5/2000	62.5/1280	72.5/520	82.5/380

Folding Engine Crane

- 4-position boom extends for hard-to-reach applications
- 4 large swivel castors provide easier positioning
- Fold-up legs reduce storage space required when not in use
- Capacity: 4000 lbs. (2 tons)
- Capacity: 38-1/2" – 59-1/2"

Model No. UAV834
Mfg. No. 024858
Price/Each \$



Lift Mate Workstation Gantries

- Equip your assembly area with an effective working concept
- Equipped with steel floor pads, pre-drilled for anchoring to floor
- To customize unit, additional options include chain blocks, festoon kit, trolley, 10' L beam for cantilever operation
- Adjustable height
- Heavy capacities and "A" frame styles are available upon request
- Capacity: 2000 lbs.
- Shipped knocked down

Model No. LT481 Capacity: 1000 lbs.
Price/Each \$

Model No. LT482 Capacity: 2000 lbs.
Price/Each \$



Shop
24/7/365

ANYTIME.
ANYWHERE.

